

Tumble dryer

T5130-LAB

Features and benefits

- Professional dryer which meets ISO6330 standard
- Durable mechanical construction, designed for professional use
- Dedicated drying programs for standard + additional programs for normal bulk drying
- Stainless steel front & Stainless steel drum
- Accurate control of exhaust air temperature
- High heating power meaning quick drying
- Combine with FOM71CLS reference washer for a complete testing solution
- **Compass Pro[®] microprocessor offers:**
 - Large display and one control knob for easy program selection
 - Language selection
 - Service program for adjustment of parameters
 - USB connection
- Residual Moisture Control for an accurate drying result and a low energy consumption
- Reversing drum for less tangling of large items
- Reversible door hanging for a convenient laundry flow
- Easy access to vital parts for simple servicing from the top and rear



Images shown are a representation of the product only and variations may occur.

Main specifications			T5130-LAB
Rated capacity,	filling factor 1:22	kg/lb	6/13
Drum volume		litre	130
Drum diameter		mm	575
Heating alternatives			
electric		kW	3.1/3.2
Consumption data*			
Total time full load		min	54
Energy consumption full load		kWh	2.95
Evaporation		g/min	56
Energy kWh/litre water evaporated		kWh/l	0.98
* At rated capacity 100% cotton load at 50% initial moisture dried to 0%. Consumption data based on bulk drying.			

Produced according to ISO 9001 and ISO 14001.

Certified with CB certificate for Low Voltage Directive and S-mark according to the Machinery Directive. Protection class IP X4D.

Electrical connections					
Heating alternative	Main voltage		Heating power kW	Total power kW	Recommended fuse A
		Hz			
Electric heated	220-230V 1 -	50/60	3.1	3.3	16
	240V 1 -	50/60	3.2	3.5	16
	380-400V 3 -	50/60	3.1	3.3	10
	415V 3 -	50/60	3.2	3.5	10

Connections		T5130-LAB
Air outlet	mm	∅ 100
Maximum air flow	m ³ /h	150
Condensate		-
Maximum static back pressure	Pa	80
Sound levels		
Sound pressure level*	dB(A)	<70
Heat emission		
% of installed power, max		15
Shipping data**		
Shipping volume	net, kg m ³	58 0.51
Accessories		
Stacking frame for mounting T5130 on top of W555H		x
Stainless steel base frame		x
Dimensions in mm		
A Width		597
B Depth		725
C Height		839
D		138
E		50
F		89
G		200
1 Operating panel 2 Door opening ∅ 370 mm 3 Electrical connection 4 Exhaust connection		

* A-weighted emission sound pressure level at workingstations.

** Average data. Crated weight/shipping volume depends on configuration. Please contact logistics for exact measures.

Standards	
ISO 6330	Domestic washing and drying for textile testing
ISO 3758	Care labelling
ISO 3759	Preparation, dimensional change
ISO 5077	Determination, dimensional change
ISO 15487	Appearance of apparel after washing & drying
ISO 7768	Smoothness appearance
ISO 7769	Creases
ISO 7770	Smoothness appearance of seams
prEN 16732	Slide (zip) fasteners
ISO 16322	Spirality after laundering
H&M	Hennes & Mauritz

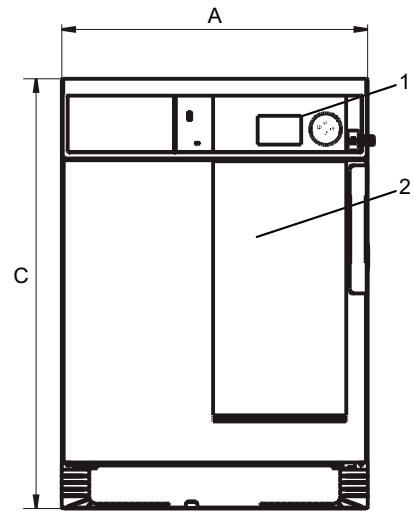

Front

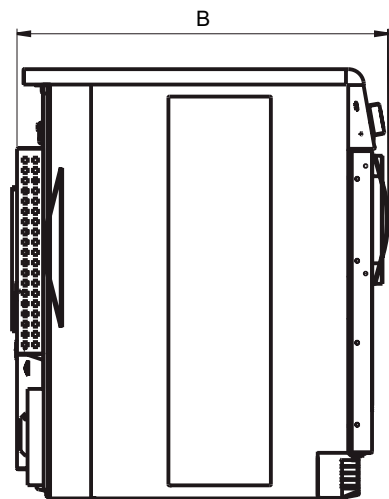

Left side

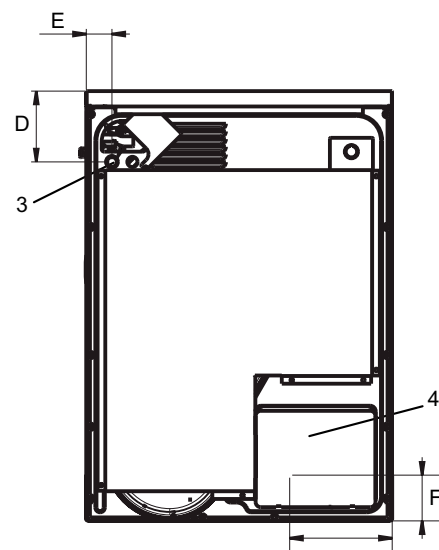

Rear side